

Me-Mover

Designed in Copenhagen

Speed

QUICKSTART GUIDE

for assembly and initial ride



0 - 25+ mph
0 - 35+ km/h



Foldable



Front and rear
disc brakes



Ø 16"
Wheel



54.5 Lbs
23.2 kg



Variable
Transmission

S20200412

! Visit our website for more information:
● <https://me-mover.com>



Watch the Me-Mover tutorials & tips:

Find videos on how to assemble, adjust and ride the Me-Mover.

<https://youtu.be/Qexn10Gc1-4>



Congratulations on your Me-Mover Speed!

Thank you for your purchase! Here is a Quickstart Guide to get you started.

Safety notifications

To highlight some of the most important safety concerns, this Quickstart Guide contains safety warnings that are featured throughout this guide.

The following symbol  **WARNING!** calls attention to a potential hazard that, if not properly addressed or avoided, could cause **serious injury or death, property damage and/or void your warranty.**

Me-Mover Speed is not a toy.

Children must only ride the Me-Mover Speed with adult supervision.

WARNING!

You must always obey your local road laws and regulations. Me-Mover is not liable for any legal infringements. It is up to the individual rider to remain up to date with the laws in their respective area.

WARNING!

Always read the User Manual before use, as this Quickstart Guide is for your convenience only. Please visit: <https://me-mover.com>

WARNING!

Any unapproved modification to the Me-Mover Speed can make it unsafe and voids your warranty. A component that is not approved, or assembly that is not correct can put high stress on your Me-Mover Speed or components. A frame, fork, or component with modifications could decrease your control and cause you to fall. Do not sand, drill, file, remove secondary retention devices, install incompatible forks, or make other modifications. Do not remove, tighten or release any bolt(s) connected to the structural frame, or connecting the frame to the transmissions. Before you add an accessory to your Me-Mover FIT consult your dealer to confirm that it is compatible and safe.

Me-Mover Speed Content Box

This is how your Me-Mover Speed is packaged in the box.

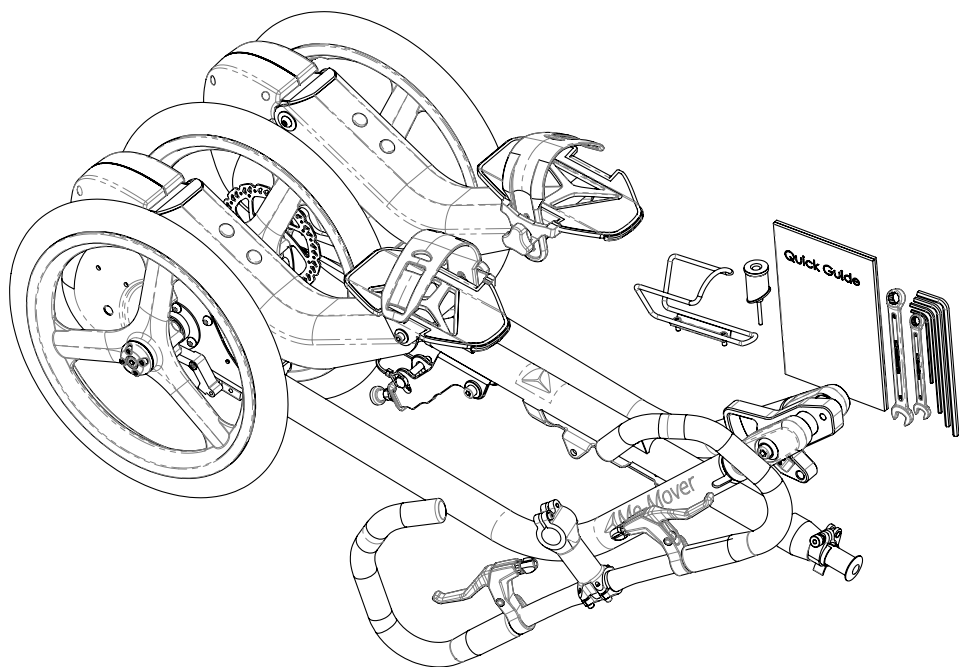

All pictures shown are for illustration purpose only. Actual product may vary due to product enhancements.



The Me-Mover Speed box contains the following pieces and sub-assemblies:

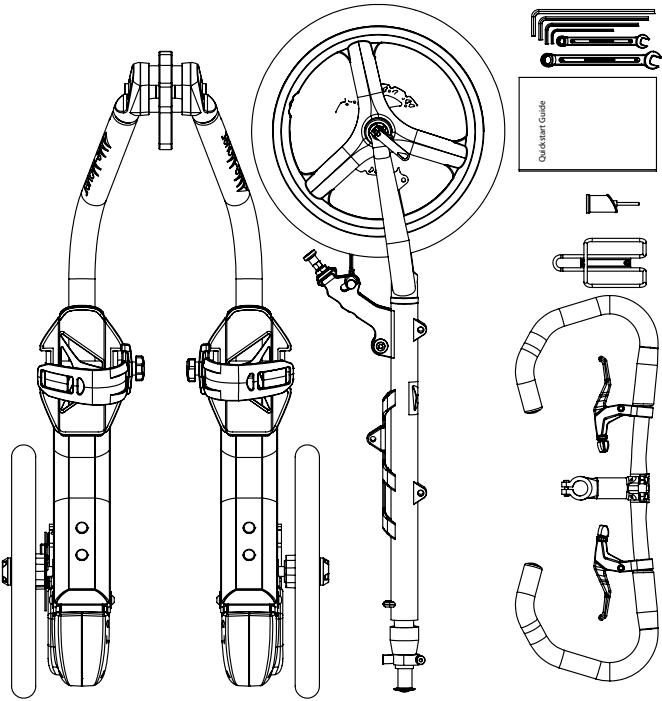

Frame with transmissions and wheels

Steering column

Handlebar

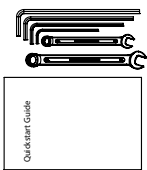

- 6 mm long hex-key
- 5 mm long hex-key
- 4 mm long hex-key
- 3 mm short hex-key
- Open end 10mm wrench
- Open end 13mm wrench

Quickstart Guide

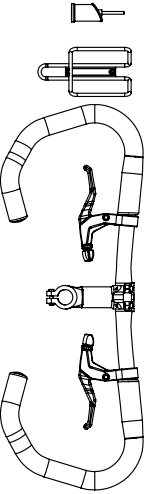

Rear-light adaptor

Waterbottle holder (optional)

AN OVERVIEW OF YOUR ME-MOVER Speed

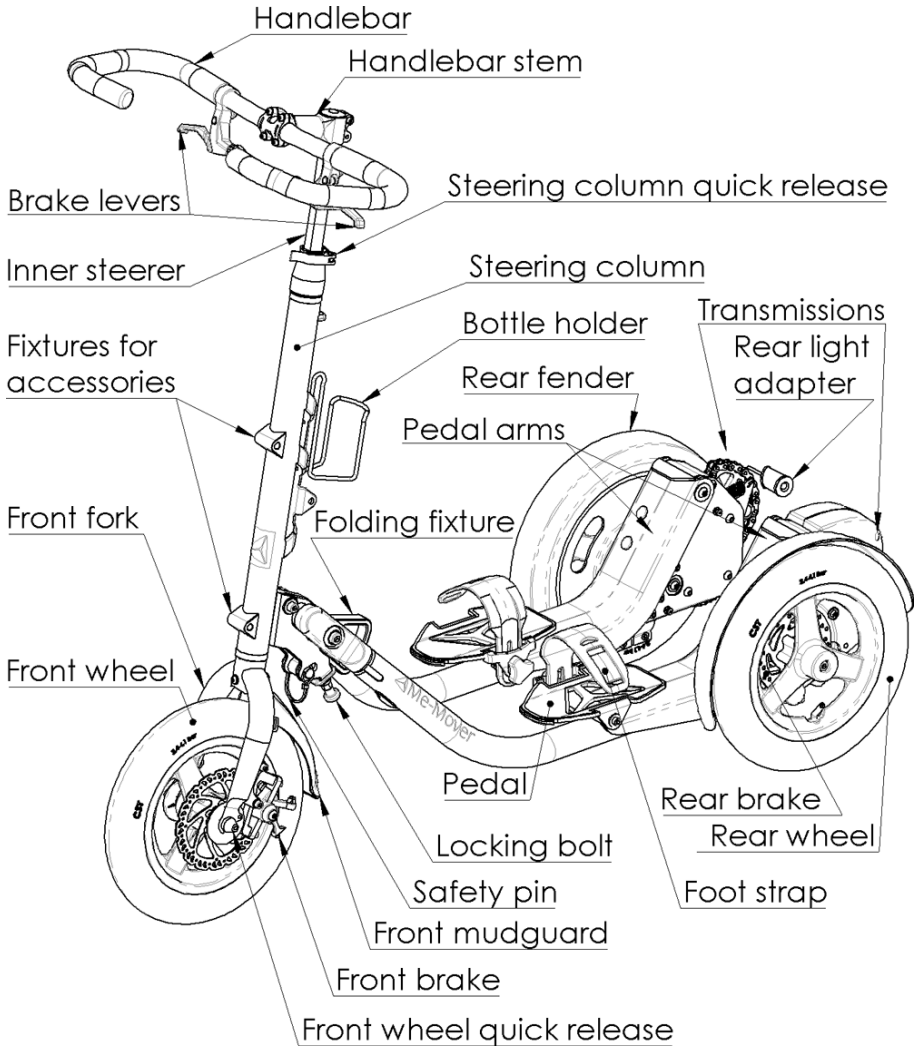

HOW TO: USE THE QUICK RELEASES

The Me-Mover Speed has two quick releases. **It is extremely important that these quick releases are tightened securely** before you use your Me-Mover Speed.

Front wheel quick release: used to secure the front wheel to the front fork.

Steering column quick release: used to adjust the height of the steering column. It can be adjusted to suit a child or an adult.

To ensure the tightness of a quick release you need to:

1. Hold the clamp OPEN while you rotate the nut in a clockwise direction.
2. Rotate the nut until you cannot close the clamp anymore.
Then release the nut slightly so you can JUST close the clamp.
3. To close the clamp push it firmly inwards.

⚠ WARNING!

To close the clamp you must use a fair amount of force, otherwise it may be too loose.

⚠ WARNING!

Always ensure that the quick releases are securely tightened sufficiently. If they come loose you must re-adjust the quick release to make it tighter. **Never drive the Me-Mover Speed without having tested that your quick releases are correctly mounted and secured.**

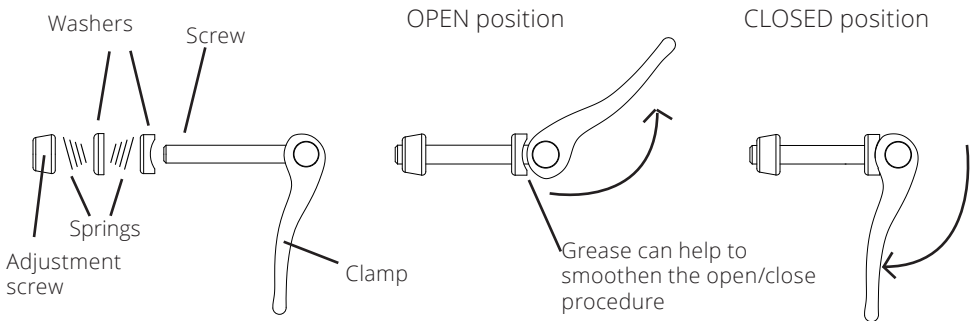

NOTE: When in open position, the adjustment screw needs to be adjusted so that closing the quick release requires some force to close the clamp. The narrow part of the spring should point towards the wheel, as illustrated.



STEP ONE: UNBOXING THE ME-MOVER

1. Open the top layer and remove the cardboard sheet.
2. Remove now the accessory bag and handlebar.

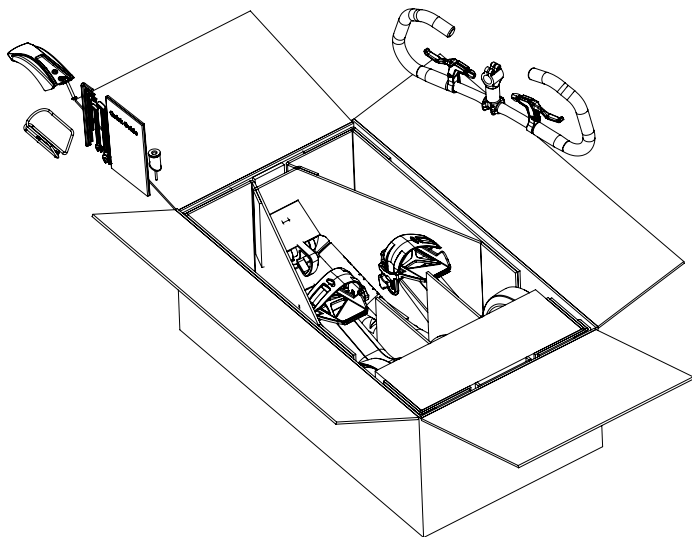

3. Remove the foam layer and cardboard pieces that hold the Me-Mover Speed in place.

4. Grab the black centre part and carefully pull it up into a vertical position. Carefully lift the product out of the box.

NOTE: The component is heavy! We urge you to use a second person to lift the object out of the box.

5. Carefully remove the front column away from the transmissions and remove it out of the box. We recommend to place the items on the cardboard you removed in the beginning. Beware: Please handle the items with care. Risk of damaging the paint.

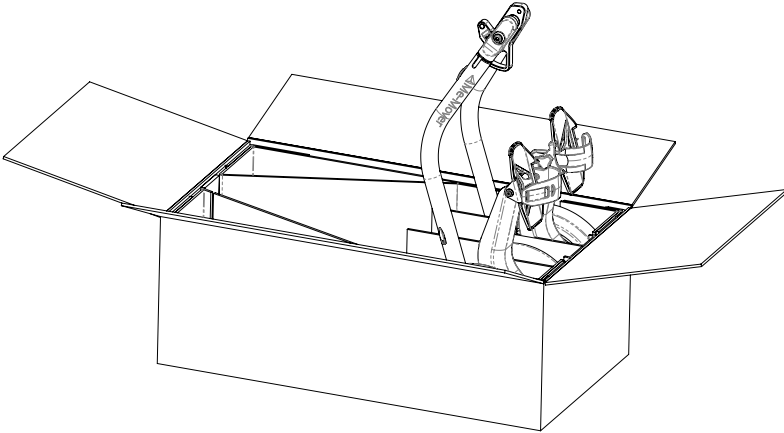

STEP TWO: HANDLEBAR AND FRONT COLUMN ASSEMBLY

1. Mount the handlebars. Place the handlebar in the stem. Place the stem bracket in the center and then insert the four M5 screws with the washers through the bracket into the stem. Tighten the screws using the 4mm hex key to maximum 5Nm. Your handlebar may already be preassembled.

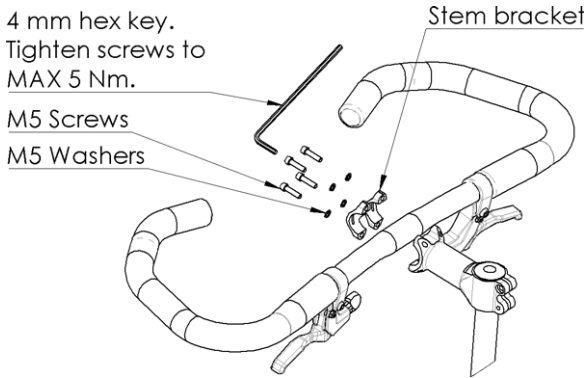

STEP THREE: CONNECTING THE FRONT AND REAR FRAME

1. Connecting the front column to the frame. Align hole **A** in the front column flange with hole **B** in the center block.

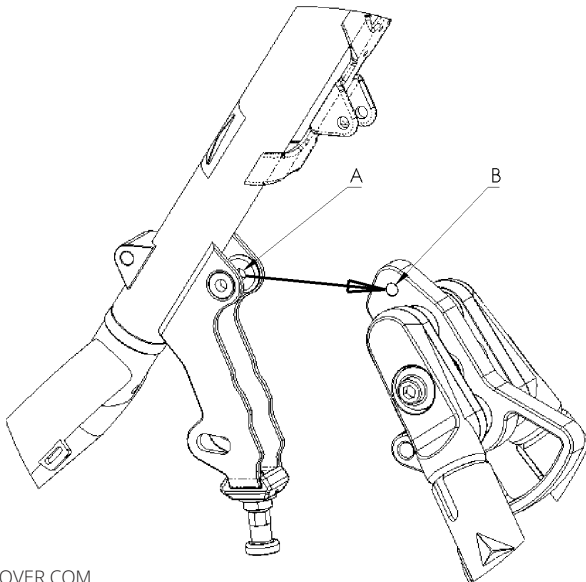

2. Connecting the front column to the frame. Front column aligned with the center block.

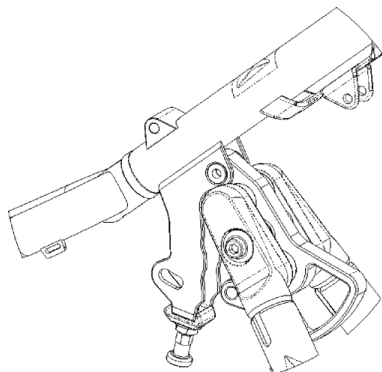

3. Connecting the front column to the frame. Insert the M8 screw **A** with the washer **B** from the left side. Place the other washer **B** on the right side and mount the M8 nut **C** on the right side.

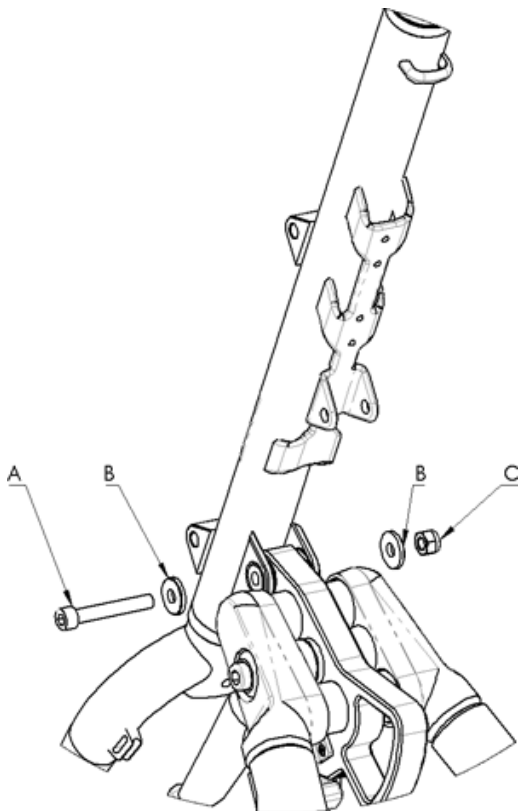

4. Connecting the front column to the frame. Front column connected with the center block.

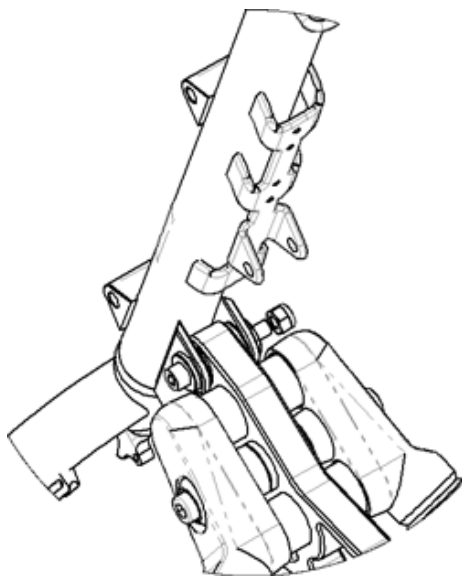

5. Connecting the front column to the frame. Use the 6mm hex key **A** and the 13mm open wrench **B** to tighten the screws. Tighten the screws to 15Nm.

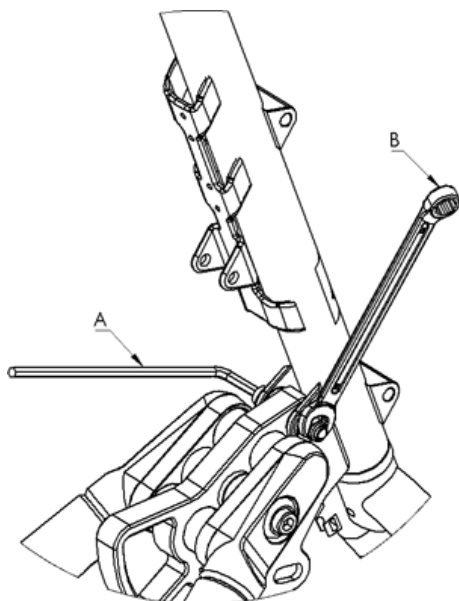

STEP FOUR: MOUNTING THE HANDLEBARS

1. Mount the handlebars. Release the quick release and pull out the inner steerer. Pull it out roughly 10cm. Whilst holding the steerer, lock the steering column quick release in place.

Important: The quick release needs to be locked firmly to avoid loosing the inner steerer into the front column!

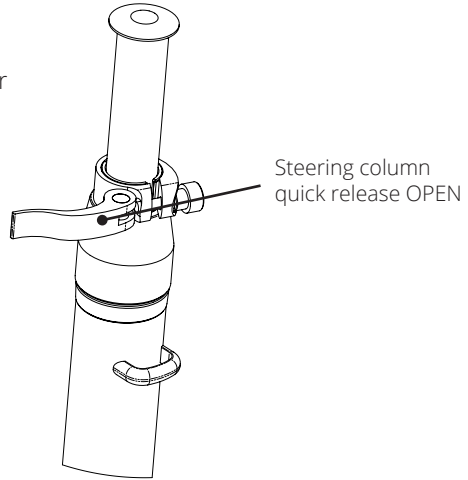

2. Remove the top cap. Firstly remove the dust cap. Put this somewhere safe. Then, use the 5mm hex key anticlockwise to unscrew and remove the top cap.

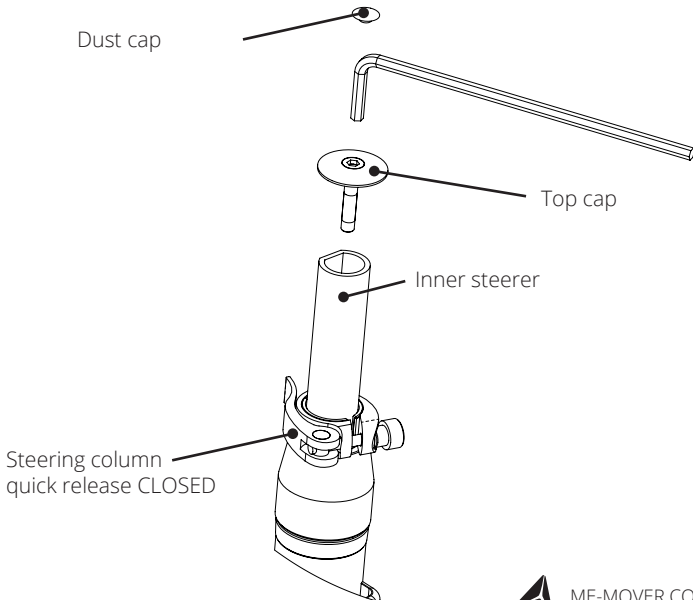

3. You are now ready to mount the bars on the steering column! Firstly, ensure the brake cables are threaded correctly as illustrated. The cables should be threaded behind the bottle holder, through the cable loop on the steering column, and then around the inner steerer below the stem as shown below.

NOTE: The left brake cable loops under the stem from the left hand side. The right brake cable loops under the stem from the right hand side. This ensures the cables are close to the frame; not interfering with the riders knees whilst riding.

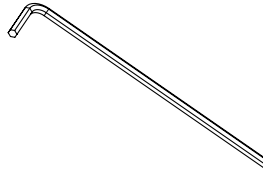
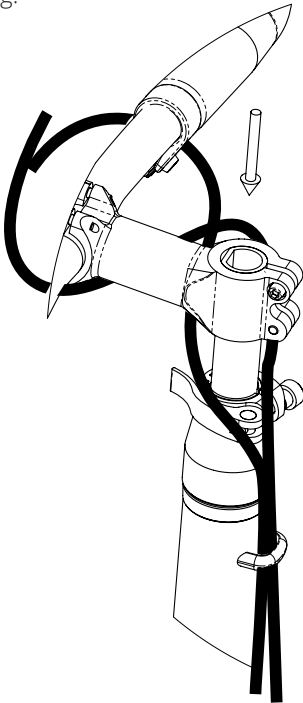
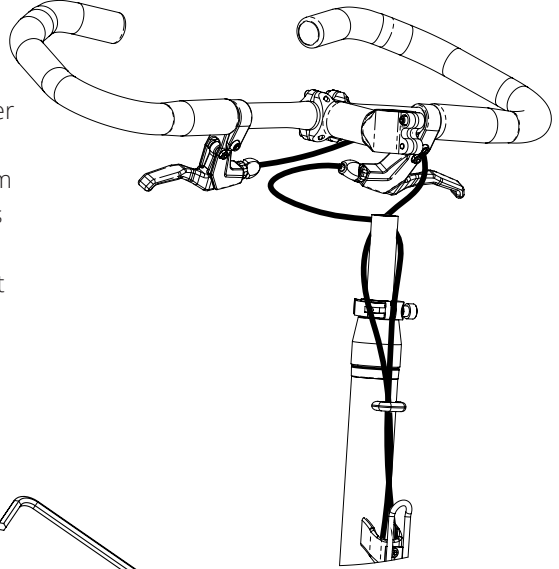

4. Insert the stem onto the steerer. Make it flush with the top of the steerer. Use the 4mm hex key to tighten the screws. Do not over tighten. Tighten to a no more than 5Nm.

NOTE: Lubricate the inner steerer with oil or grease.

⚠ WARNING!

Do not tighten the screws with more than 5Nm. 5Nm corresponds to a 20cm long wrench with a force of 2.5kg.

STEP FIVE: MOUNTING THE BRAKE CABLES

1. Fitting the brake cables. The cables should be threaded behind the bottle holder, through the cable loop on the steering column, and then around the inner steerer below the stem as shown below.

NOTE: The left brake cable loops under the stem from the left hand side. The right brake cable loops under the stem from the right hand side. This ensures the cables are close to the frame; not interfering with the riders knees whilst riding.

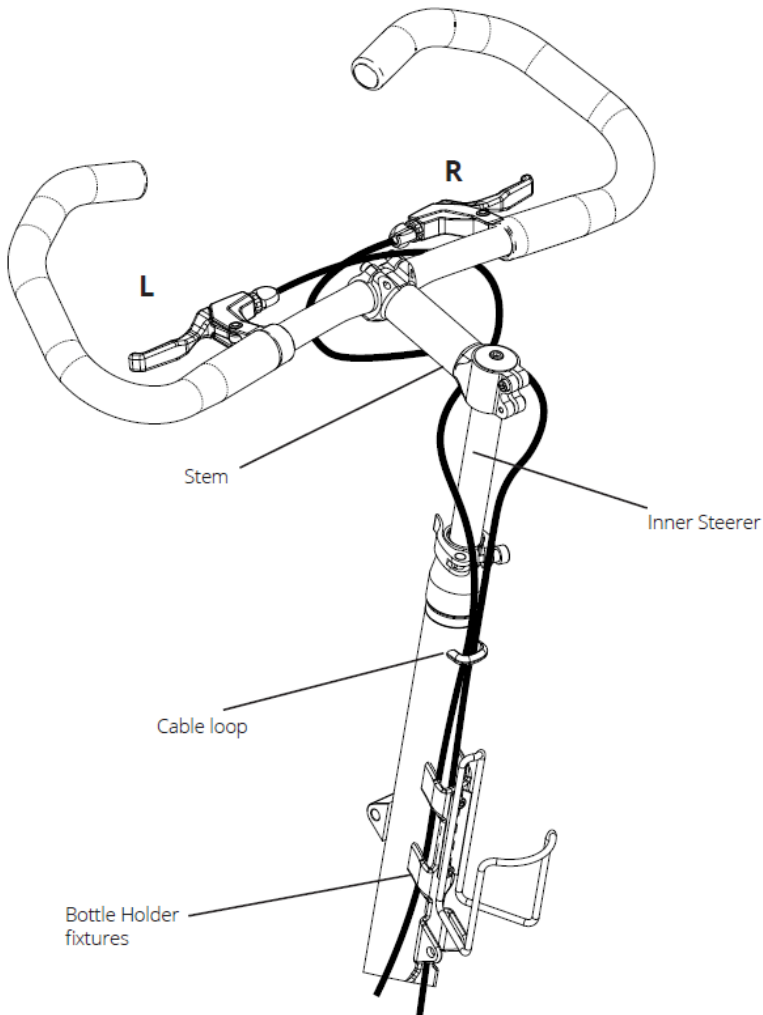

2. Final checks: The handlebar should look like below. Remember, if the cables are not organised correctly they may get in the way when riding.

NOTE: The left brake cable loops under the stem from the left hand side. The right brake cable loops under the stem from the right hand side. This ensures the cables are close to the frame; not interfering with the riders knees whilst riding.

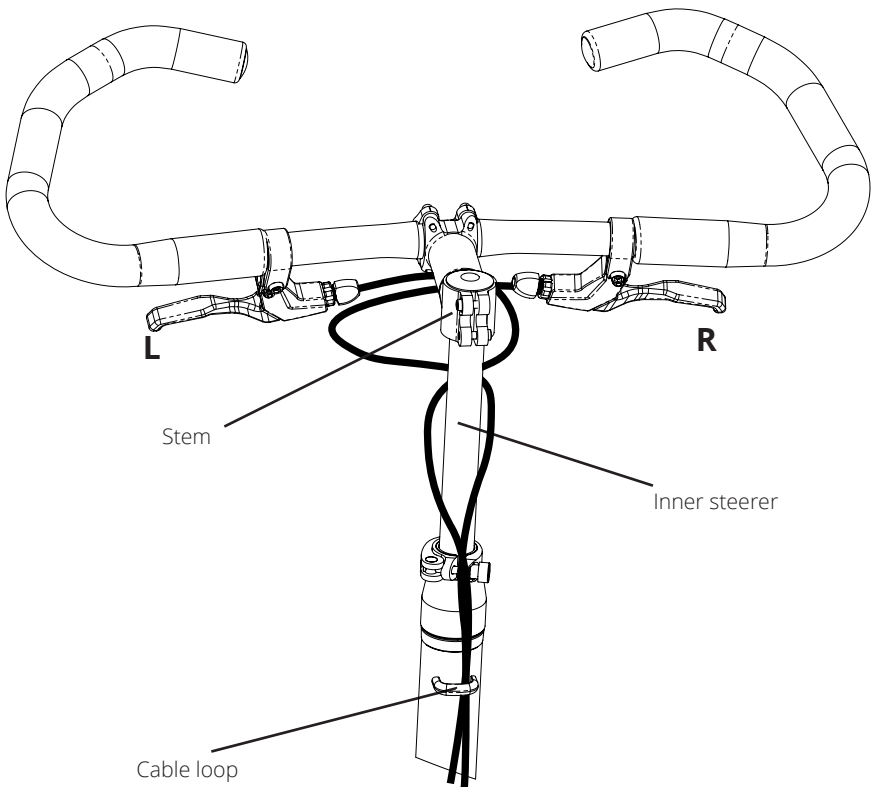

⚠ WARNING!

Make sure that the front cable is not twisted before you drive your Me-Mover. The cable may twist if you accidentally turn the handlebar by 360 degrees.



3. Connect the brake cables with the brake levers. Pull the brake handle and insert the end cap into the slot in the brake handle.

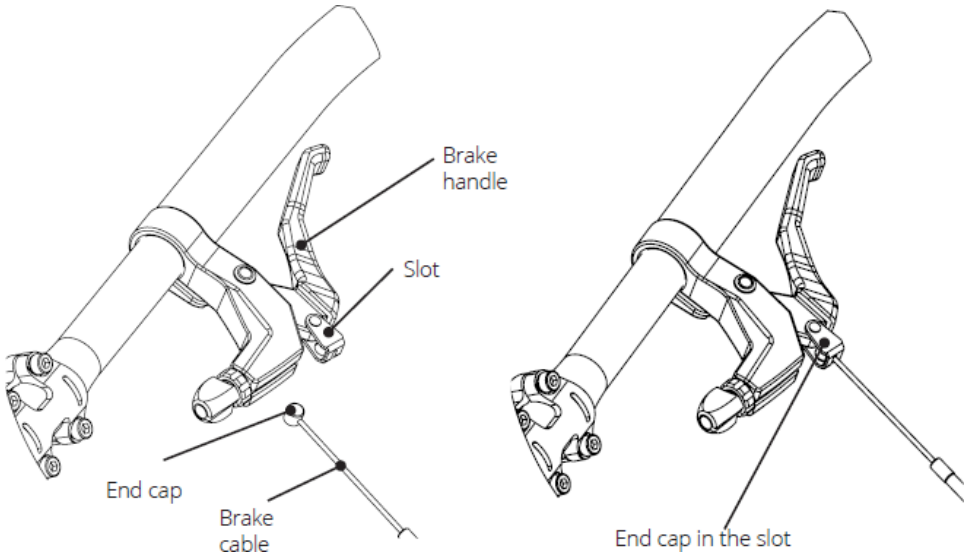

4. Align the lock nut and adjustment screw and slide the cable into the groove. If necessary, pull the brake cable housing so more cable is exposed. Screw the lock nut and adjustment screw tight.

NOTE: Please take note of which cable operates the front and the rear brake when doing this step. There may be local laws regulating how your brakes need to function.

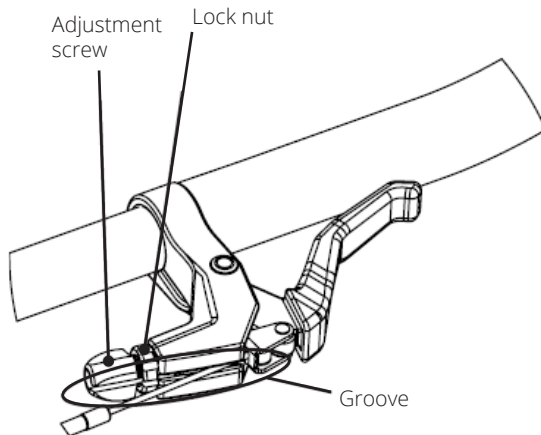

HOW TO: ENGAGE THE PARKING BRAKE

The brake lever may or may not have the parking brake feature.
Subject to availability.

1. Put light pressure on the red lever.

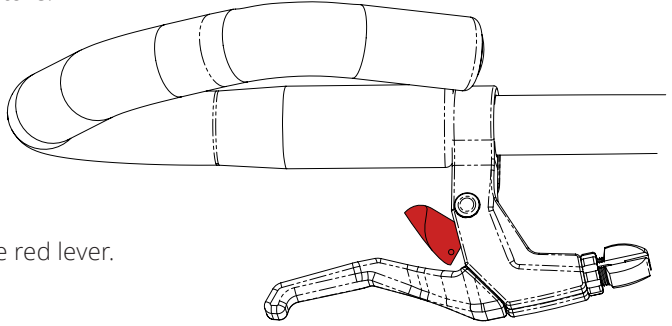

2. Whilst keeping light pressure on the red lever, pull the brake lever until you hear a click.

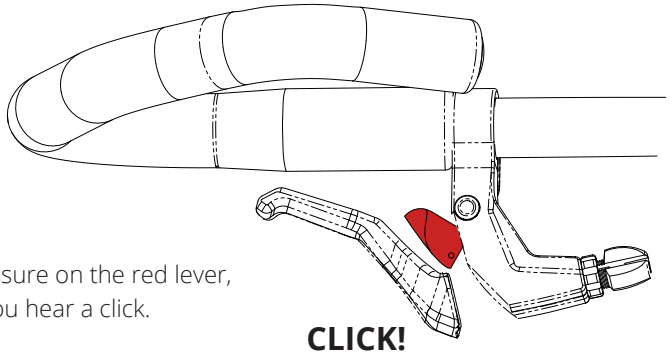

3. Maintain light pressure on the red lever.
Release the brake lever. The parking brake will now be engaged.

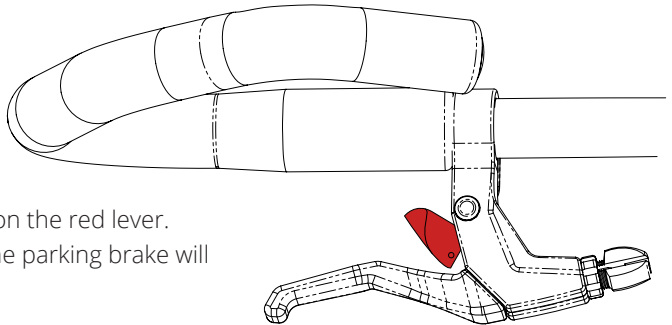

In order to disengage, just pull the brake lever. You do not need to touch the red lever.

HOW TO: UNFOLD YOUR ME-MOVER Speed

1. Remove the safety pin: Open the safety clip **A** by releasing the spring with your thumb. Remove the pin.

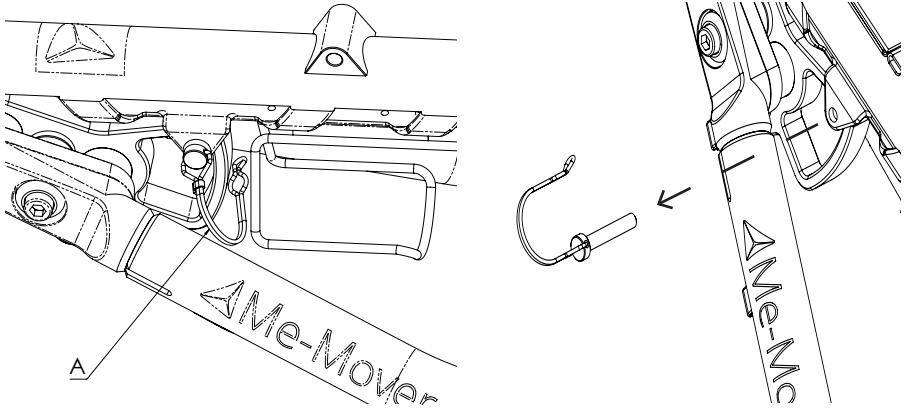

Engage the front brake whilst pushing forward on the handlebar. You should hear a click. This click is important to ensure safe riding.

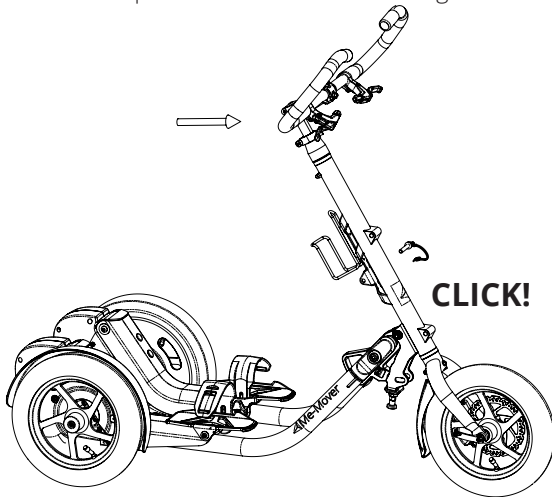

Don't forget to re-insert the safety pin. Do not ride the Me-Mover without the safety pin.

⚠ WARNING!

If you do not hear the 'CLICK' sound it means the locking bolt has not been secured in place. If the locking bolt does not click into place, do not use the Me-Mover Speed under any circumstance. There should be no space around the locking bolt. Remember to re-insert the safety pin.



HOW TO: FIT THE SAFETY PIN

NOTE: When fitting the safety pin, ensure the attached wire loops around the pin as shown below. Do not ride the Me-Mover Speed without correctly fitting the safety pin.

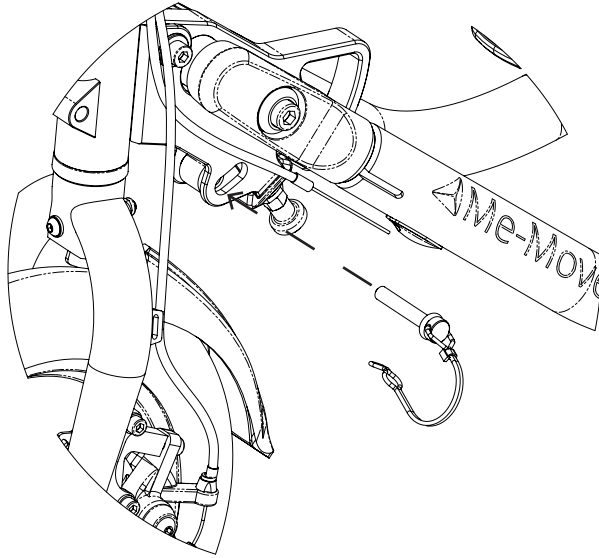

NOTE: Ensure the attached wire loops around the pin as shown below. Do not ride the Me-Mover Speed without correctly fitting the safety pin.

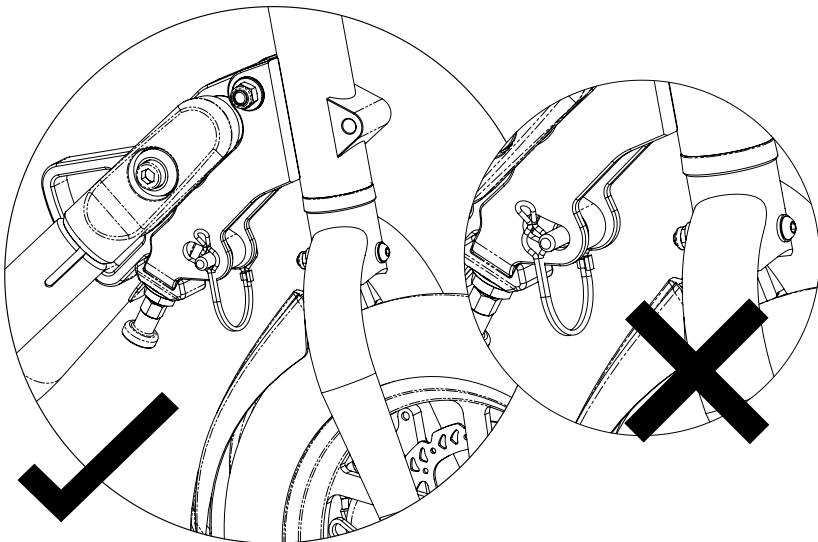

HOW TO: FOLD YOUR ME-MOVER Speed

Remove the safety pin and adjust the handlebar all the way down.

1. Engage the front brake.
2. Press forward on the handlebar.
3. Whilst pressing forward, pull the locking bolt downwards. Remember to keep pressing forward on the handlebar. This may take some force else the bolt will not release.
4. The Me-Mover will release. Fold the Me-Mover Speed. Reinsert the pin to lock the frame when it is folded!

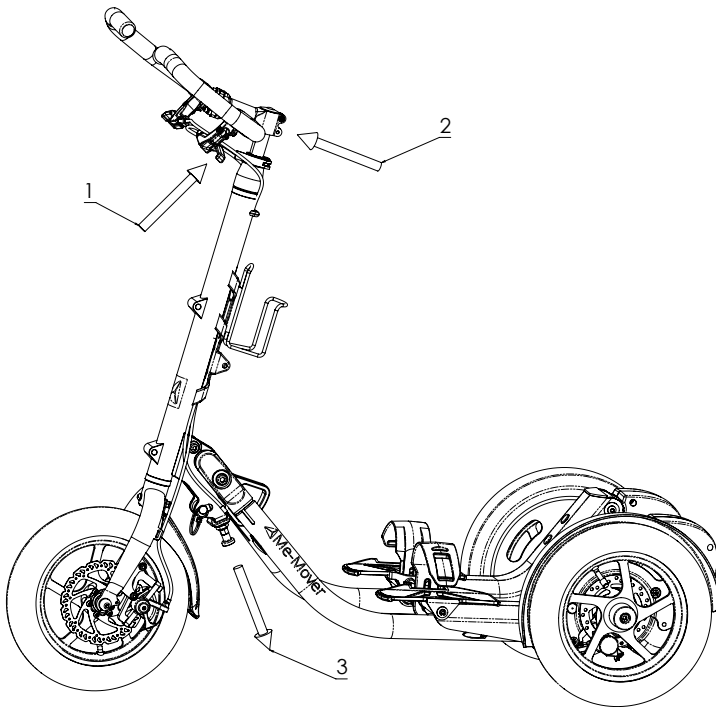

⚠ WARNING!

Be careful with plastic covers of the transmission: they can crack if too much force is put on them.

HOW TO: RIDE SAFELY

It is important to stay safe on the road and be careful of other road users. Use your common sense and make sure you always abide by local laws and regulations.



Always wear a helmet!



Use lights at night!



Maximum weight of rider:
100 kg /220 lbs



No riding on ice!



No stunt driving!



No wheelies!

REGULARLY CHECK BRAKES. Please test the brakes are functioning properly.

Conduct a security test before riding. Test both the front and the rear brakes before getting on your Me-Mover Speed Walk alongside your Me-Mover Speed and try to brake with each brake individually. You should be able to stop the Me-Mover Speed when in motion with each brake. The rear brake will bring you to a gradual halt.

⚠ WARNING! The front brake will bring you to a sudden halt, so please use it cautiously. In wet or slippery conditions, and when carving around corners, please be very cautious with the front brake.

⚠ WARNING! Do not use the Me-Mover Speed if the brakes do not work properly. If they are not working properly, please refer to the User Manual for instructions on how to adjust the brakes.

If you continue to have problems, please contact your nearest retailer, or our headquarters at support@me-mover.com

RIDING INSTRUCTIONS



⚠️ WARNING!

Do not try the Me-Mover Speed in a crowded or high-traffic area for the first time.

The Me-Mover FIT offers a totally unique riding feel that requires only minutes to learn. Follow these simple instructions to start riding your new Me-Mover Speed.

1. Wear a helmet.
2. Find an area without traffic to practice in. Ensure that it is a straight, safe stretch with a flat surface.
3. Adjust the handlebar height to a comfortable position before mounting the Me-Mover Speed. Release the steering column quick release clamp. This will allow you to slide the steering column up and down to your desired height. Hold the clamp OPEN while you rotate the nut in a clockwise direction. Rotate the nut until you cannot close the clamp anymore. At this point release the nut slightly so you can JUST close the clamp.

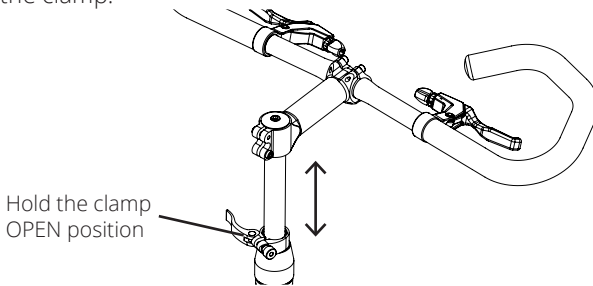

⚠️ WARNING!

Always be sure that the quick release is fastened securely! For detailed instructions refer to "How To Use The Quick Releases" on page 7.

⚠️ WARNING!

Do not heighten past the maximum mark. If the maximum mark on the inner steerer is visible you have heightened it too much. This will weaken the stability of the inner steerer and will risk injury and/or damage to your Me-Mover Speed.

4. Make sure both pedals are in the bottom position.

5. Adjust the foot straps: loosen the foot strap by gently rotating the foot strap screw in a counterclockwise direction. Do not unscrew it entirely. Slide your foot onto the pedal until the ball of your foot is slightly ahead of the pedal axle. This will put less strain on your achilles tendon and calf muscle.

Tighten the strap by rotating the foot strap screw in a clockwise direction. The strap should fit comfortably around your foot.

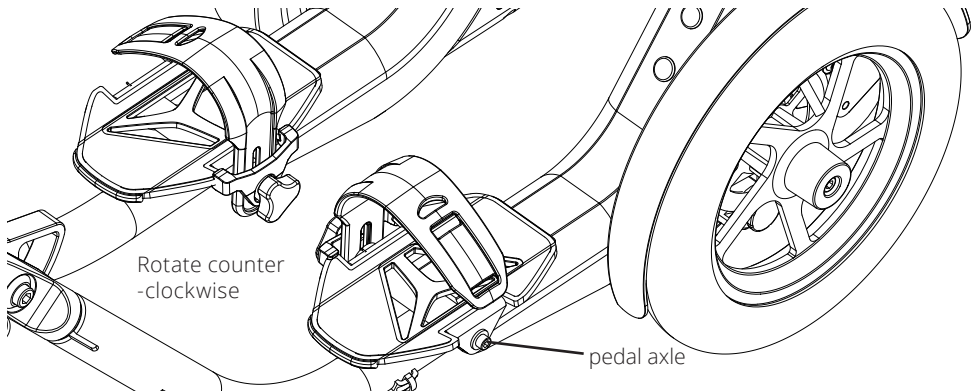

⚠ WARNING!

Positioning the ball of your feet behind the pedal axle can cause injury and/or cramp in your calf muscle over time. Make sure the straps are securely tightened.

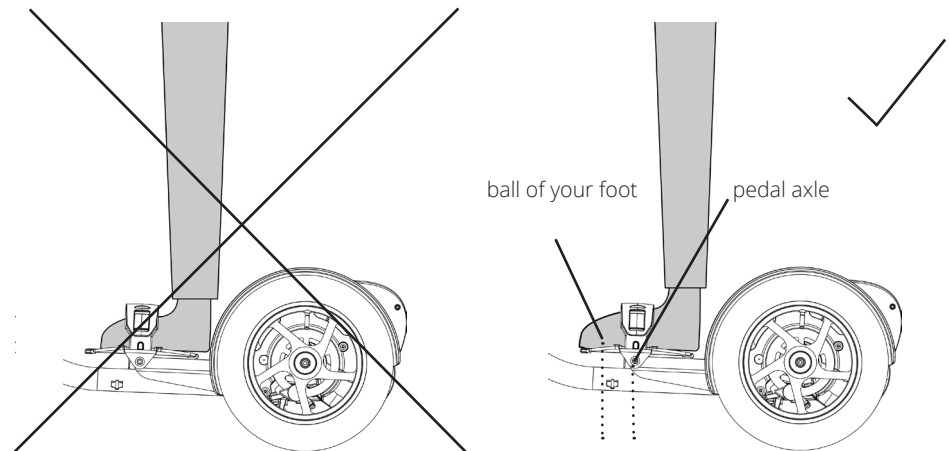

6. Stand next to your Me-Mover Speed.

7. Grab the handlebar and hold ONE brake tight. Place one foot onto the pedal at a time. For the purpose of stability, place your foot closest to the Me-Mover Speed on the pedal first.

8. Keep holding ONE brake tight and when you have placed both of your feet on the pedals, lean gently to either side to find your balance.

9. Lift one leg to the highest comfortable point.

10. Release the brake. You will move slightly forward. At this point you should lift your other foot. **Only concentrate on the lifting motion.** Alternate lifting your feet as though you are walking up a flight of stairs. Eventually you will lift your second foot before the first foot will reach the bottom of the pedal stroke. There is no need to forcibly push the pedal downwards because your body weight will automatically push the pedal down.

11. The higher the pedal rises, the lower the gear is. The position of the pedal stroke determines the gear.

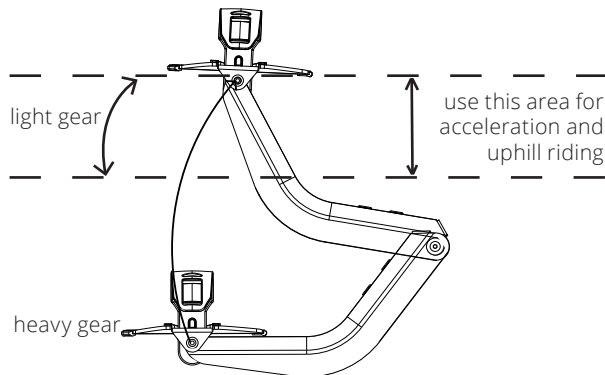

⚠ WARNING!

Due to the very compact design and short wheel-base it is easy to do an unintended 'wheelie'. Do not jump on the pedals to avoid falling or damaging your transmissions. Always lean forwards with your arms flexed when riding the Me-Mover Speed. Keep your centre of gravity between the front wheel and the rear wheels at all times.

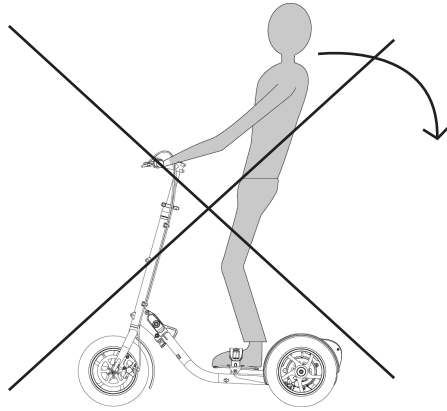

⚠ WARNING!

Although you can learn to ride the Me-Mover Speed in minutes, **do not ride on challenging terrain or in high traffic areas until you are practiced and have 100% control of the Me-Mover Speed.** It is your own responsibility to practice sufficiently on the Me-Mover Speed before entering crowded areas. Always wear protective gear, such as a helmet and protective pads. Never ride the Me-Mover Speed while intoxicated.

Thank you for purchasing a Me-Mover. We hope you have as much fun on it as we did designing it. We look forward to hearing about your Me-Mover journey.

Happy Me-Moving!

A stylized, handwritten signature in black ink, appearing to read 'Jonas' followed by a large, looping flourish.

Jonas Eliasson
CEO and Founder

FOLLOW US ON OUR SOCIAL MEDIA AND KEEP YOU UPDATED:

Facebook WW:

<https://www.facebook.com/thememover>



Facebook DK:

<https://www.facebook.com/thememoverdanmark>



Instagram:

<https://www.instagram.com/thememover/>



Youtube:

<https://www.youtube.com/user/TheMemover>



LinkedIn:

<https://dk.linkedin.com/company/me-mover>



JOIN OUR COMMUNITY

Join the **Me-Mover ambassador group on Facebook** to join the conversation and share your own ideas: <https://www.facebook.com/groups/185521488228560>

SUPPORT:

If you have any further questions, contact us at **support@me-mover.com** and we will get back to you as soon as possible.

